

**Computer-controlled, High-speed, Bar-tacking Machine
(for sewing hooks and eyes / snaps)**

高速電子模様罫止めミシン（前カン・スナップ付け仕様）

**LK-1910SS5241Z / 5242Z
5261Z / 5010Z**

PARTS LIST

HOW TO MAKE USE OF THIS PARTS LIST

1. As to "#01" and "#02" refer to the "Note" given at the bottom of the respective pages.
2. Codes on the "Qty" column
 - Each numeral indicates the number of parts required.
 - "0.1" and "2.5" indicate the length (in meters) of the respective parts.
3. Parentheses mean that the corresponding part is a subpart that constructs an assembly part.
4. Dotted lines on the Figures indicate assembly parts.

パーツリストご利用に際して

1. リストページの#01、#02等の印は、ページ下の"注記"の説明をご参照下さい。
2. 数量欄の数字は、個数を表し、0.1、2.5等の数値は、長さ（単位メートル）を表します。
3. 数量欄の（ ）は、組部品を構成している子部品であることを意味します。
4. イラストページの-----枠は、組構成であることを意味します。

CONTENTS

目次

1. LK-1910-5241/5261 SEWING HOOKS ATTACHMENT COMPONENTS	1
LK-1910-5241/5261 分離型前カン押えオス関係	
2. LK-1910-5242 SEWING EYES ATTACHMENT COMPONENTS	3
LK-1910-5242分離型前カン押えメス関係	
3. WIPER COMPONENTS	5
ワイパ関係	
4. HAND SWITCH COMPONENTS	6
手元スイッチ関係	
5. NEEDLE BAR & TABLE COMPONENTS	7
針棒・脚卓関係	
6. CONTROL BOX & ACCESSORIES PARTS COMPONENTS	9
電装・付属品関係	
7. OPTION & ATTACHMENT COMPONENTS (1)	11
オプション・アタッチメント関係 (1)	
8. OPTION & ATTACHMENT COMPONENTS (2)	13
オプション・アタッチメント関係 (2)	
NUMERICAL INDEX OF PARTS	15
索引	

Note : When there are parts not be listed in this parts list,
Please refer to LK-1910/1920 PARTS LIST (No.1243)

注記：このパーツリストに記載されていない部品については、
LK-1910/1920 パーツリスト (No.1243) をご参照下さい。

1. LK-1910-5241/5261 SEWING HOOKS ATTACHMENT COMPONENTS

LK-1910-5241/5261 分離型前カン押えオス関係

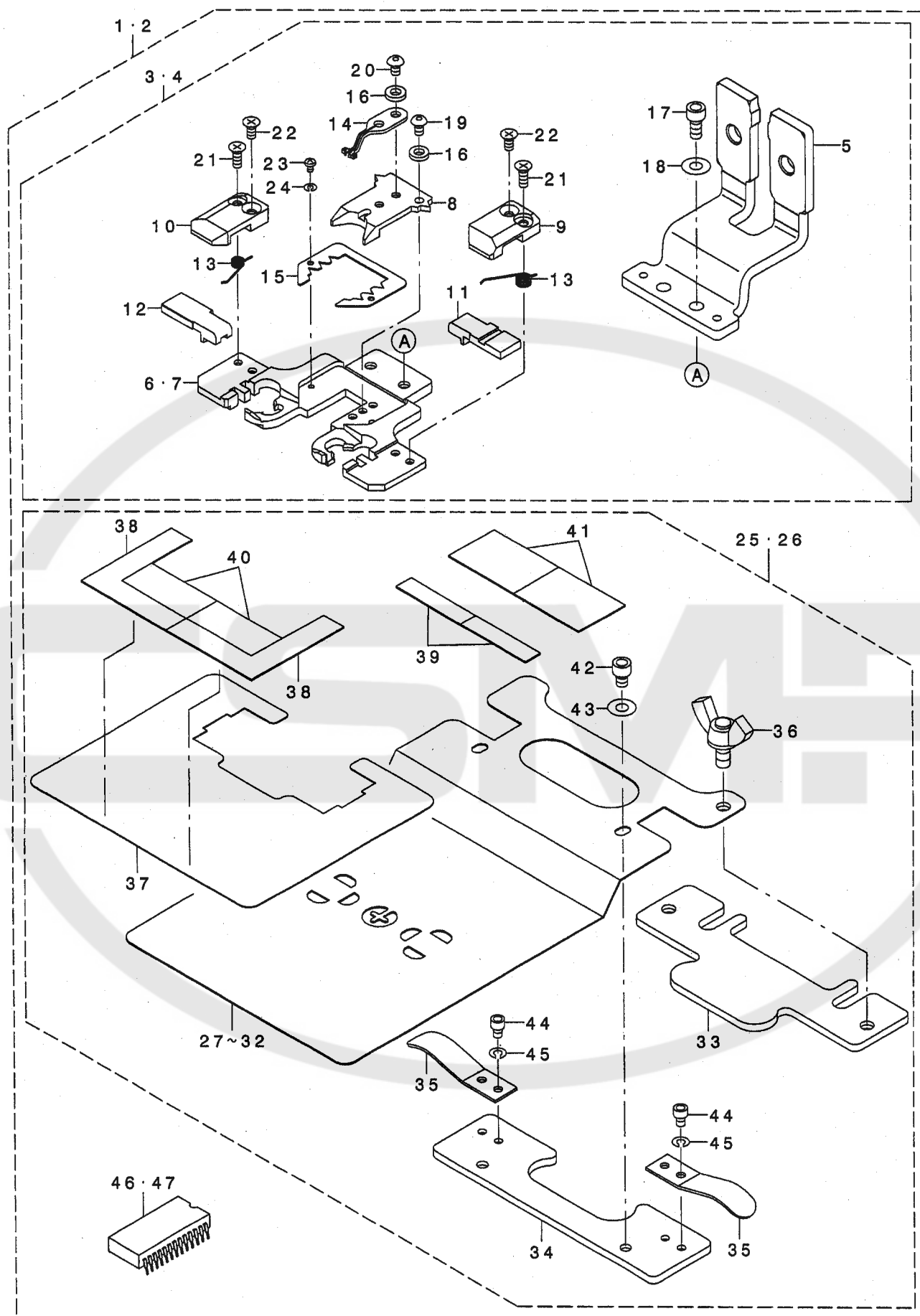

2. LK-1910-5242 SEWING EYES ATTACHMENT COMPONENTS

LK-1910-5242分離型前カン押えメス関係

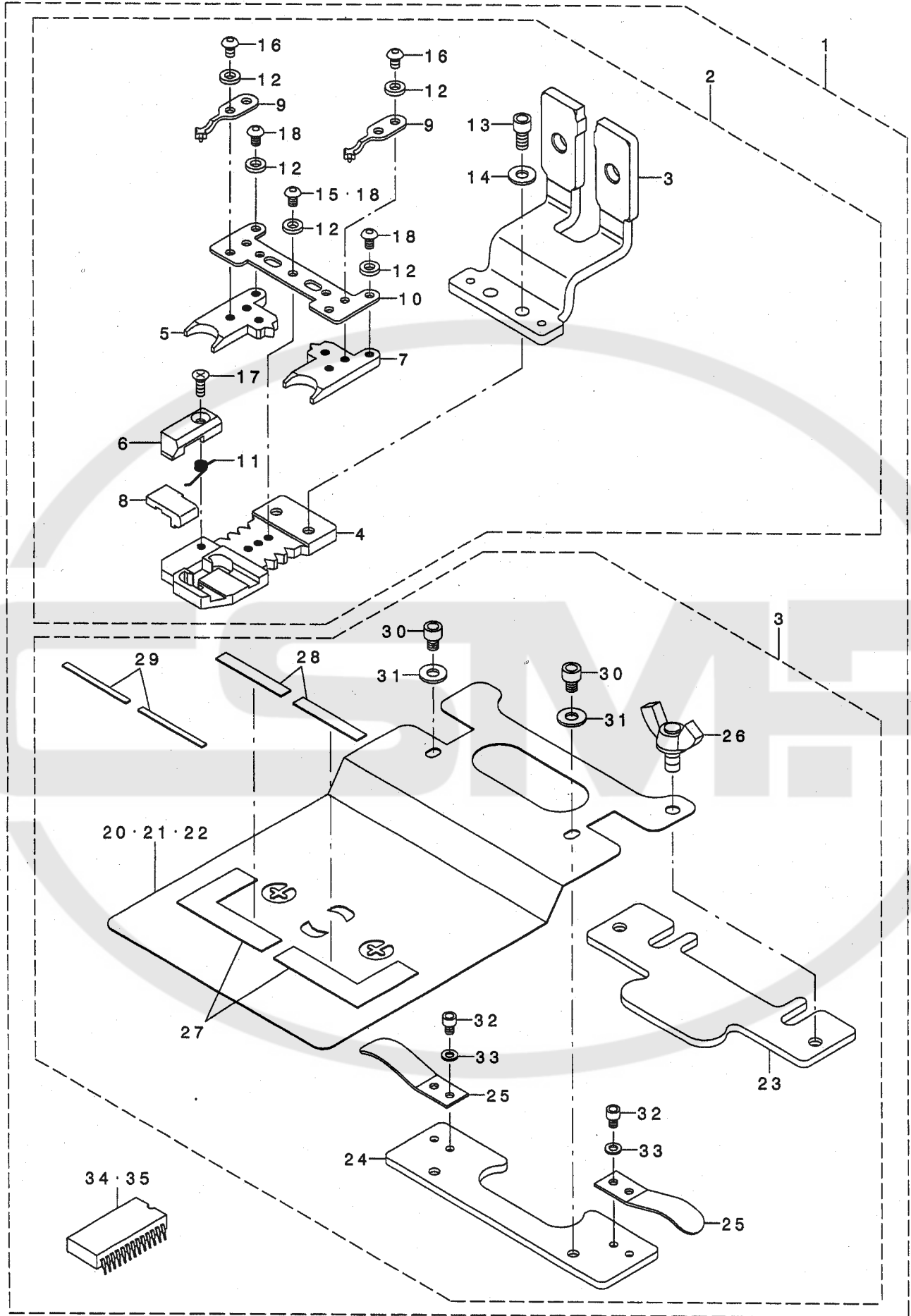

REF. NO	NOTE	PART NO.	DESCRIPTION	品名	Qty
1		400-05744	SEWING EYES ATTACHMENT ASM.	マエカンオサエソウクミメスM508 608	1
2		400-04830	SEWING EYES ATTACHMENT ASM.	フソリカタマエカンオサエクミメス508608	(1)
3		142-17764	SLIDING PLATE COMPL.	イツタイヌノオサエアシスハリイタクツコウ	(1)
4		400-04832	BASE	ハース	(1)
5		400-04833	SNAP AUXILIARY BASE, LEFT	スナップホジヨハースヒダリ	(1)
6		400-04834	COVER	カハ	(1)
7		400-04835	SNAP AUXILIARY BASE, RIGHT	スナップホジヨハースミキ	(1)
8		400-04836	PUSHER	プツシャ	(1)
9		400-04837	SNAP HOLDER	スナップホルダ	(2)
10		400-04838	SNAP AUXILIARY PLATE	スナップホジヨイタ	(1)
11		400-04814	PUSHER SPRING	プツシャハネ	(1)
12		400-04829	SPACER	スパサ	(9)
13		SM-6040802-TN	SCREW	ロツカクアナホルト M4X0.7 L=8	(2)
14		WP-0450826-SC	WASHER 4.5X10X0.8	ヒラサカネ 4.5X10X0.8	(2)
15		SM-3030552-TN	SCREW M3 L=5	マルネジ M3 L=5	(1)
16		SM-3030552-TN	SCREW M3 L=5	マルネジ M3 L=5	(4)
17		SM-1030801-SR	SCREW M3 L=8	チラネジ M3X0.5 L=8	(1)
18		SM-3030552-TN	SCREW M3 L=5	マルネジ M3 L=5	(4)
19		400-04831	FEED PLATE ASM. EYES M-508	シタイタクミメスM-508 608	(1)
20		400-04839	FEED PLATE	シタイタ	(1)
21	#01	400-04843	FEED PLATE 5 EYES M-508	シタイタ5 M-508メヌ	(1)
22	#01	400-04844	FEED PLATE 10 EYES M-508	シタイタ10 M-508メヌ	(1)
23		400-04818	FITTING PLATE	トリツケプレート	(1)
24		400-04819	FITTING AUXILIARY PLATE	トリツケホジヨプレート	(1)
25		400-04820	LEVER	レハ	(2)
26		161-37804	WING SCREW	チヨウネジ	(1)
27		400-04840	FIXING L GAUGE	コテイLゲージ	(2)
28		400-04841	GAUGE 3	3ゲージ	(2)
29		400-04842	GAUGE 3.5	3.5ゲージ	(2)
30		SM-6040502-TN	SCREW	ロツカクアナホルト	(2)
31		WP-0450826-SC	WASHER 4.5X10X0.8	ヒラサカネ 4.5X10X0.8	(2)
32		SM-6030402-TN	SCREW M3X4	ロツカクアナツキホルト	(4)
33		WS-0310002-KR	SPRING WASHER 3.1X5.9X0.7	ハネサカネ 3.1X5.9X0.7	(4)
34		HL-0119400-04	MEMORY IC(M508)	メモリ IC(M508)	(1)
35		HL-0119400-03	MEMORY IC(M608)	メモリ IC(M608)	(1)

NOTE (注記) #01....OPTIONAL PARTS

オプシヨソ部品

3. WIPER COMPONENTS

ワイパ関係

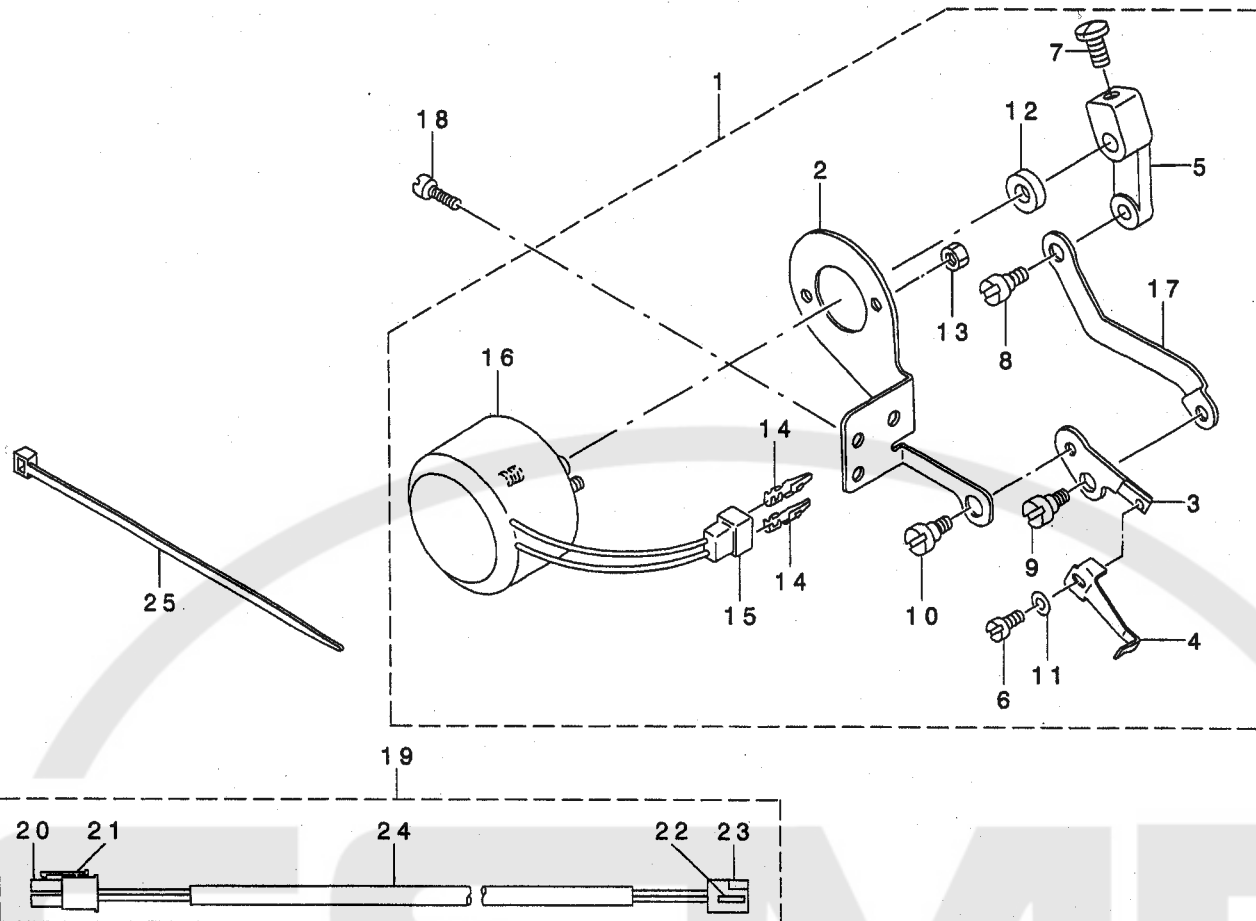

REF. NO	NOTE	PART NO.	DESCRIPTION	ヒソメイ	Qty
1		B2101-220-0A0	WIPER ASM.	ワイパ - クミ	1
2		B2104-220-000	SOLENOID INSTALLING PLATE	ワイパ - マグ ネット トリツケイタ	(1)
3		B2106-220-000	WIPER INSTALLING PLATE	ワイパ - タイ	(1)
4		B2107-210-000	WIPER	ワイパ	(1)
5		B2102-205-00A	WIPER ARM	ワイパ - ウデ	(1)
6		SS-6090630-TP	SCREW 9/64-40 L=6	ヒラネシ 9/64-40 6=6	(1)
7		SS-7111120-SP	SCREW 11/64-40 L=10.5	マルヒラネシ 11/64-40 L=10.5	(1)
8		SD-0600352-SP	HINGE SCREW	ダソネシ	(1)
9		SD-0640321-SP	HINGE SCREW D= 6.35 H= 3.2	ダソネシ D=6.35 H=3.2	(1)
10		SD-0640321-SP	HINGE SCREW D= 6.35 H= 3.2	ダソネシ D=6.35 H=3.2	(1)
11		WP-0371016-SD	WASHER 3.7X8X1	ヒラサガネ 3.7X8X1	(1)
12		WP-0561616-SC	WASHER 5.6X16X1.6	ヒラサガネ 5.6X16X1.6	(1)
13		NM-6040003-SC	NUT M4	ロツカクナツト M4	(2)
14		HP-0002002-00	PIN-SHAPE TERMINAL, MALE	ナイロンコネクタピン	(2)
15		HK-0188000-20	2-POLE PLUG	ナイロン プラグ	(1)
16		B2101-220-000	WIPER SOLENOID	ワイパ - マグ ネット	(1)
17		B2103-220-000	WIPER CONNECTING PLATE	ワイパ - レンケツイタ	(1)
18		SS-7110840-SP	SCREW 11/64-40 L=7.8	マルヒラネシ 11/64-40 L=7.8	2
19		M9060-592-0A0	CONNECTING CABLE ASM.	ヨコハライワイパ - チユウケイケ-ブルクミ	1
20		HK-0346100-2B	HOUSING	ハウジング	(1)
21		HK-0346400-00	PIN CONTACT	ピン タ-ミナル	(2)
22		HP-0006002-10	CONNECTOR PIN	ナイロンコネクタピン	(2)
23		HK-0188200-20	RECEPTACLE 2P	リセア タクル 2P	(1)
24		HW-0005900-20	CABTYRE CORD	キャブ タイヤコ-ト	(1.7)
25		EA-9500B01-00	CABLE BAND	ソクセンハン ト	1

4. HAND SWITCH COMPONENTS

手元スイッチ関係

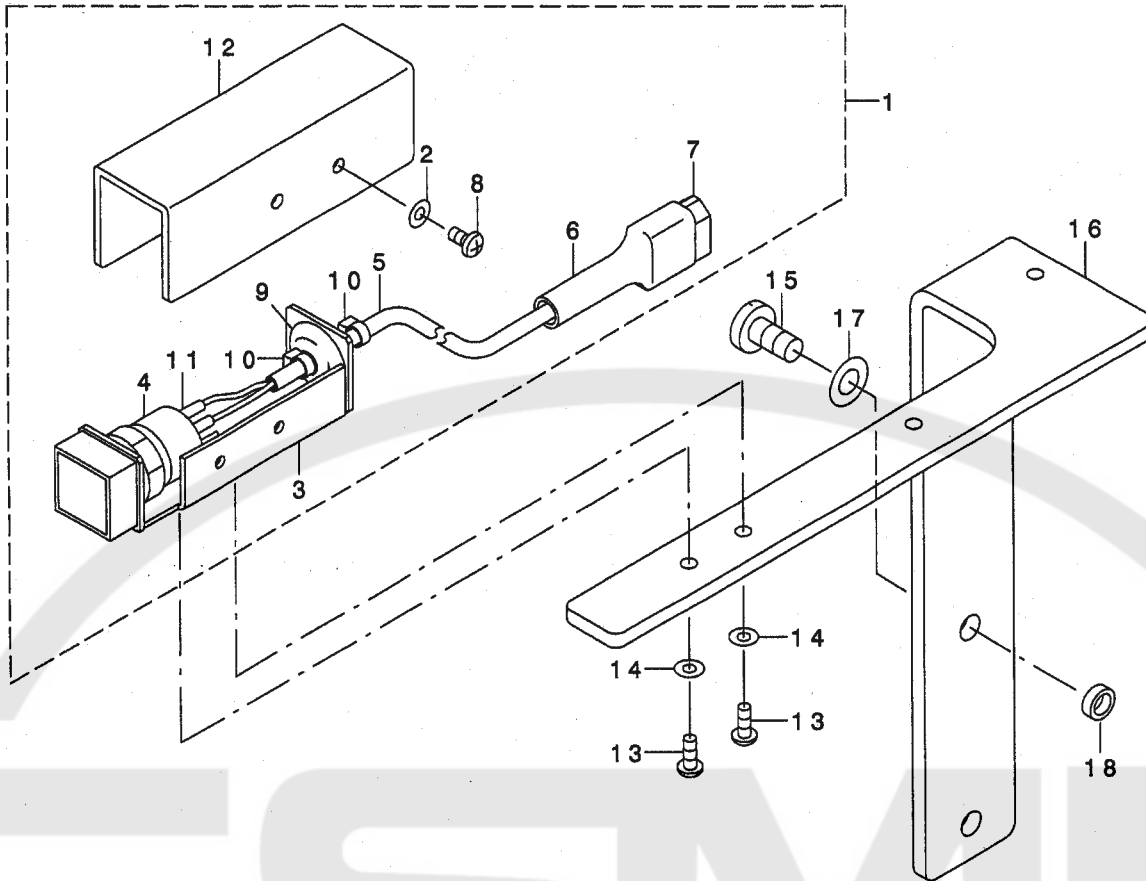

REF. NO	NOTE	PART NO.	DESCRIPTION	ヒソメイ	Qty
1		D8310-205-KAA	NEAR SWITCH A ASM.	テモトスイッチ A クミ	1
2		WP-0320501-SC	WASHER M3	ヒラサガネ 3.2X7X0.5	(2)
3		D1129-205-KOA-A	SWITCH BASE	シュトウスイッチトリツケダイ	(1)
4		HA-0028300-00	PUSH SWITCH	プッシュスイッチ	(1)
5		HW-5001400-00	2-C CABLE	キャブタイヤコート 0.18X12X2	(1.6)
6		MAT-81126T00	2-POLE PLUG COVER	2P プラグカバー	(1)
7		MAI-15040000	2-POLE PLUG	2P ナイロンプラグ	(1)
8		SM-4030601-SN	SCREW M3 X 6	ナハコネシ M3X0.5 L=6	(2)
9		D2570-205-KOA	GLOMMET	グロメット	(1)
10		EA-9500B00-00	CLIP CV-70S	ケツソクハント 60	(2)
11		E8760-452-D00	TUBE 0.015M	スミチューブ	(0.06)
12		G6214-345-000	START SWITCH COVER	スタートスイッチカバー	(1)
13		SM-4030801-SN	SCREW M3 L=8	ナハコネシ M3 L=8	2
14		WP-0320501-SC	WASHER M3	ヒラサガネ 3.2X7X0.5	2
15		SS-7151210-SP	SCREW 15/64-28 L=12	マルヒラネシ 15/64-28 L=12	2
16		400-04861	HAND SWITCH FITTING PLATE	テモトスイッチトリツケイタ	1
17		WP-0641601-SD	WASHER M6	ヒラサガネ ミガキマル M6	2
18		B1504-280-000	COLLAR	オツサケ リンク クミサガネ	2

5. NEEDLE BAR & TABLE COMPONENTS

針棒・脚卓関係

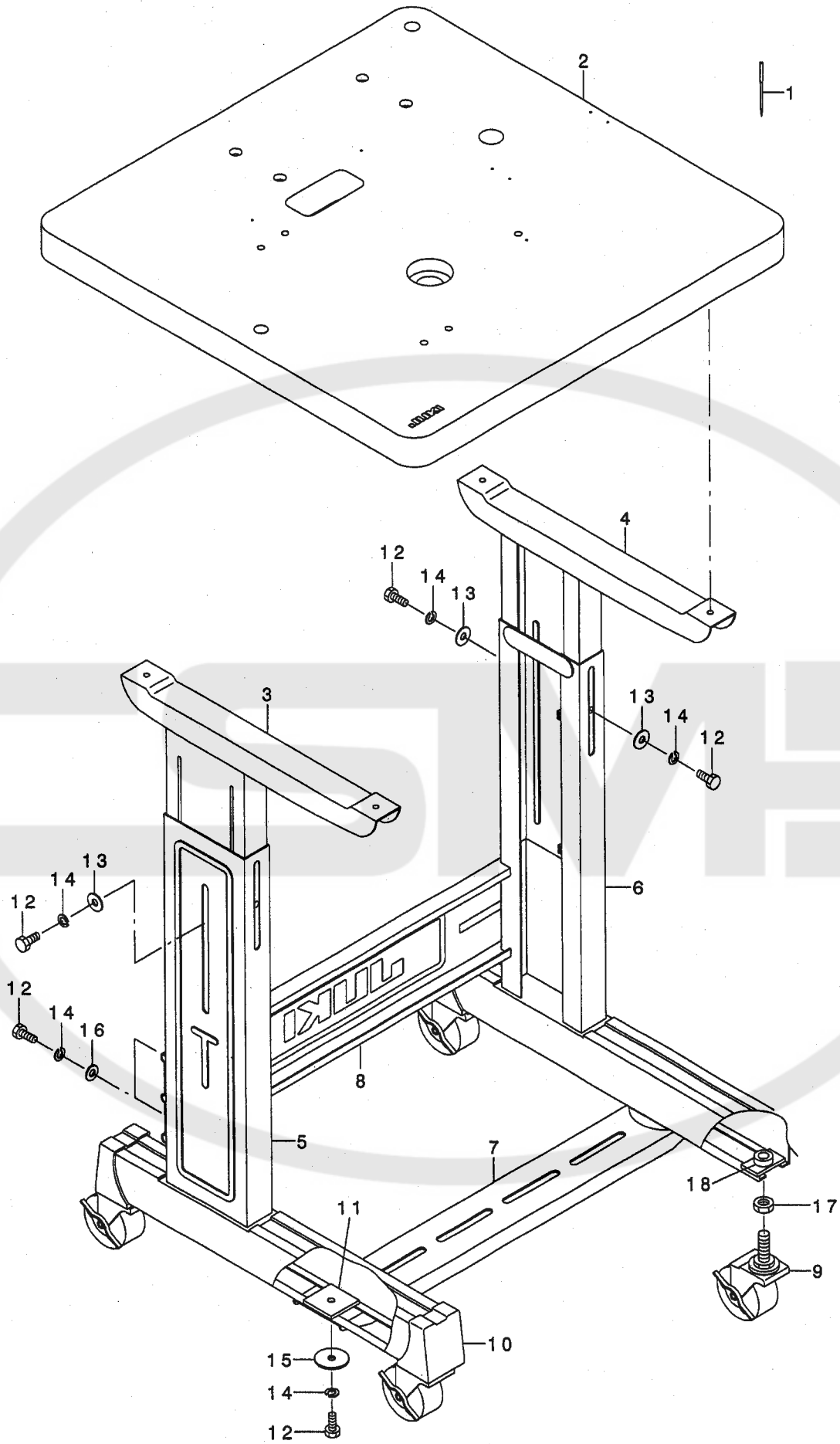

REF. NO	NOTE	PART NO.	DESCRIPTION	品名	Qty
1		MDP-170B1400	NEEDLE DPX17 #14	ハリ DPX17 #14	1
2		400-04860	TABLE	テーブル	1
3		B8101-205-OBA	UPPER STAND ASM., LEFT	ウツキヤク ケツゴ ウ(ヒタリ)	1
4		B8102-205-OAA	UPPER STAND COMPL., RIGHT	ウツキヤク ケツゴ ウ(ミキ)	1
5		180-77909	LOWER LEG, LEFT	シチュウケツゴ ウ(ヒタリ)	1
6		180-78006	LOWER LEG, RIGHT	シチュウケツゴ ウ(ミキ)	1
7		D8307-205-KOA	LEG BOTTOM SUPPORT	フミイタササエタ イ	1
8		D8308-205-KOA	STAND SIDE SUPPORT	ヨコシチュウ	1
9		170-07204	CASTER	キヤスタ-	4
10		180-78204	CAP	キヤクト タ イキャツブ	4
11		170-07402	NUT	44カクナツト	2
12		SM-9082023-SE	SCREW M8 L=20	ロツカクホ ルト M8 L=20	12
13		170-07907	WASHER	Tガ タチヨウセツイタヨウヒラサ カネ	6
14		WS-0861410-KR	SPRING WASHER 8.6X15X1.4	ハネサ カネ 8.6X15X1.4	12
15		170-08004	WASHER	フミイタササエタ イヨウヒラサ カネ	2
16		170-08103	WASHER	Zウツハリヨウヒラサ カネ	4
17		NM-6120003-SE	NUT M12	ロツカクナツト M12 シュ	4
18		170-07105	RING	Zガ タカナキヤクリンク	4

6. CONTROL BOX & ACCESSORIES PARTS COMPONENTS

電装・付属品関係

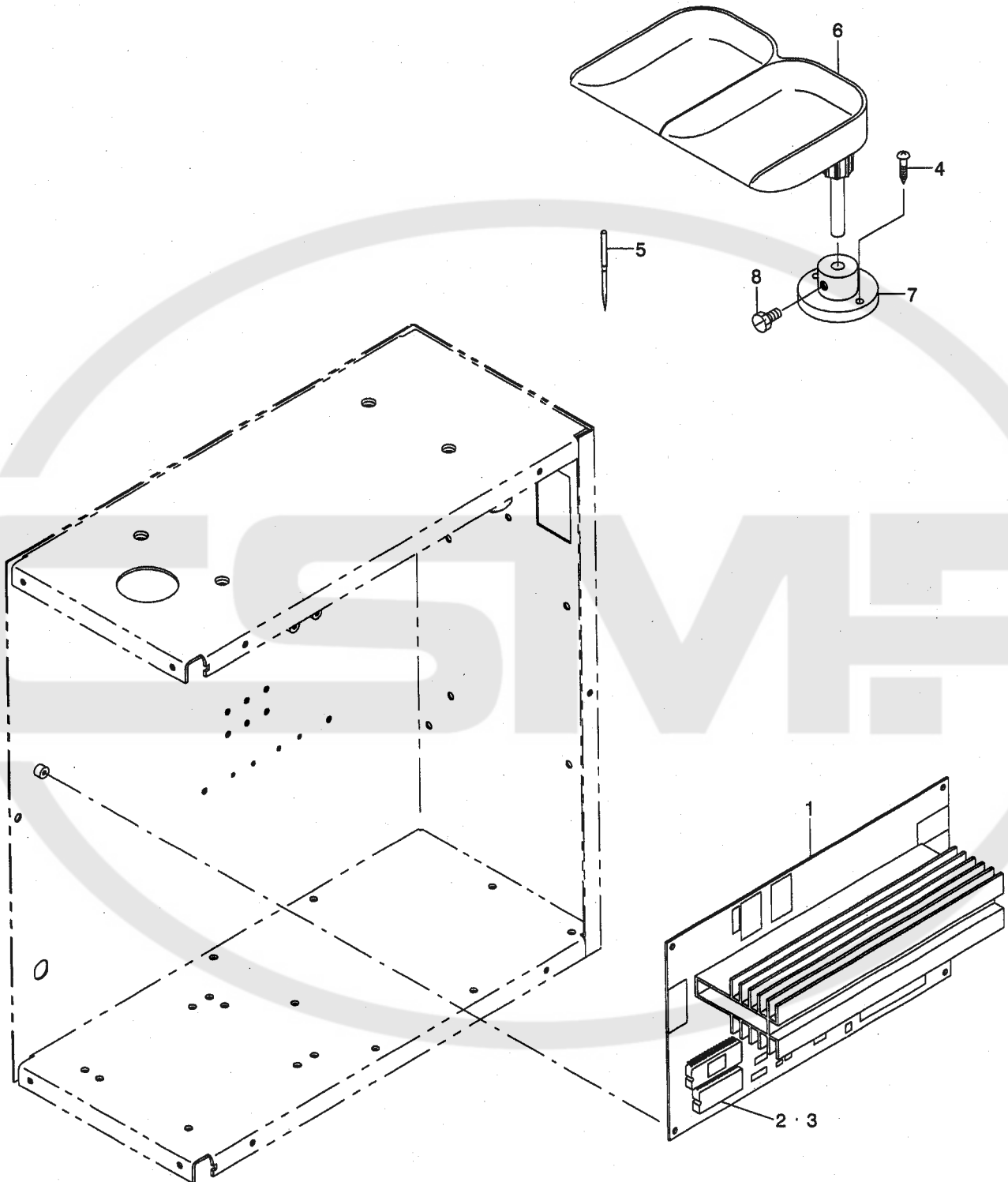

REF. NO.	NOTE	PART NO.	DESCRIPTION	ト ヲ キ イ	Qty
1		M8601-592-ABO	MAIN CIRCUIT BOARD A ASM.	メインキハソエイキミ	1
2		HL-0119400-04	MEMORY IC (M508)	メモリ IC (M508)	1
3		HL-0119400-03	MEMORY IC (M608)	メモリ IC (M608)	1
4		SS-9151210-TP	SCREW 15/64-28 L=11.8	ロツカクホルト 15/64-28	1
5		MDP-170B1402	NEEDLE DPX17#14-2	DPX17#14-2	1
6		178-48458	BUTTON TRAY ASM.	ホタソウケザラクミ	1
7		178-48508	BUTTON TRAY BASE	ホタソウケザラダイ	1
8		SK-3412001-SE	WOOD SCREW D=4.1 L=20	カマトリツケビス	2



7. OPTION & ATTACHMENT COMPONENTS (1)

オプション・アタッチメント関係 (1)

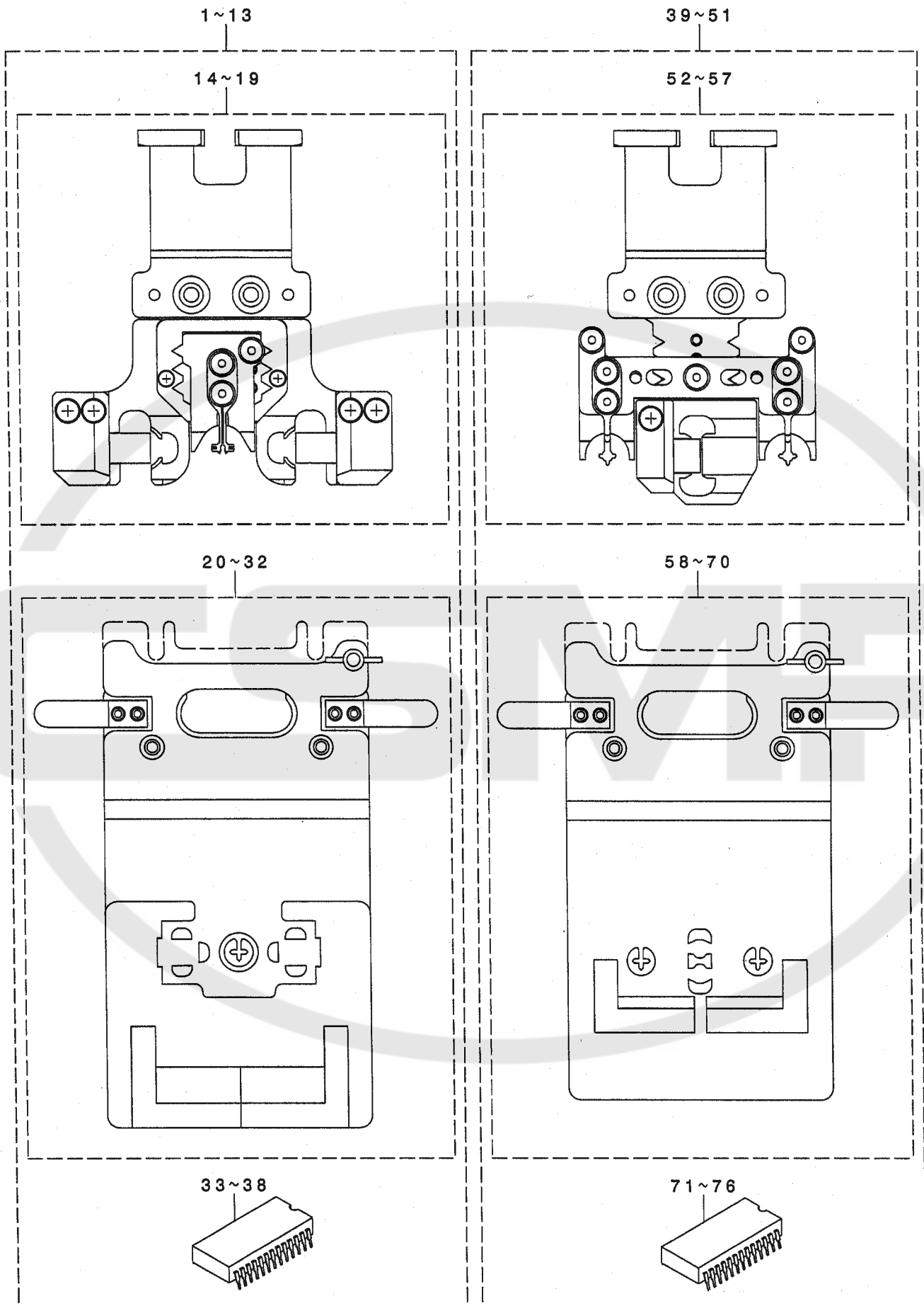

REF. NO	NOTE	PART NO.	DESCRIPTION	品名	Qty
1		400-06231	SEWING HOOKS ATTACHMENT ASM.	マエカノサエソウクミメ5MM(M508)	1
2		400-06232	SEWING HOOKS ATTACHMENT ASM.	マエカノサエソウクミメ10MM(M508)	1
3		400-06233	SEWING HOOKS ATTACHMENT ASM.	マエカノサエソウクミメ5MM(M608)	1
4		400-06234	SEWING HOOKS ATTACHMENT ASM.	マエカノサエソウクミメ10MM(M608)	1
5		400-06237	SEWING HOOKS ATTACHMENT ASM.	マエカノサエソウクミメ(M525)	1
6		400-06238	SEWING HOOKS ATTACHMENT ASM.	マエカノサエソウクミメ5MM(M525)	1
7		400-06239	SEWING HOOKS ATTACHMENT ASM.	マエカノサエソウクミメ10MM(M525)	1
8		400-06240	SEWING HOOKS ATTACHMENT ASM.	マエカノサエソウクミメ(M528, M670)	1
9		400-06241	SEWING HOOKS ATTACHMENT ASM.	オサエソウクミメ5MM(M528, M670)	1
10		400-06242	SEWING HOOKS ATTACHMENT ASM.	マエカノサエソウクミメ(M520)	1
11		400-06243	SEWING HOOKS ATTACHMENT ASM.	マエカノサエソウクミメ5MM(M520)	1
12		400-06244	SEWING HOOKS ATTACHMENT ASM.	マエカノサエソウクミメ10MM(M520)	1
13		400-06245	SEWING HOOKS ATTACHMENT ASM.	マエカノサエソウクミメ(M533)	1
14		400-04806	SEWING HOOKS ATTACHMENT ASM.	アソリカ タマエカノサエソウクミメM508	(1)
15		400-04850	SEWING HOOKS ATTACHMENT ASM.	アソリカ タマエカノサエソウクミメM-608	(1)
16		400-05746	SEWING HOOKS ATTACHMENT ASM.	アソリカ タマエカノサエソウクミメM525	(1)
17		400-05754	SEWING HOOKS ATTACHMENT ASM.	マエカノサエソウクミメM528 670	(1)
18		400-05766	SEWING HOOKS ATTACHMENT ASM.	アソリカ タマエカノサエソウクミメM520	(1)
19		400-05787	SEWING HOOKS ATTACHMENT ASM.	アソリカ タマエカノサエソウクミメM533	(1)
20		400-05774	FEED PLATE ASM. 5MM M508 HOOKS	ツタイタクミ5MM(M508)	(1)
21		400-05775	FEED PLATE ASM. 10MM M508 HOOKS	ツタイタクミ10MM(M508)	(1)
22		400-05776	FEED PLATE ASM. 5MM M608 HOOKS	ツタイタクミ5MM(M608)	(1)
23		400-05777	FEED PLATE ASM. 10MM M608 HOOKS	ツタイタクミ10MM(M608)	(1)
24		400-05748	FEED PLATE ASM. M525 HOOKS	ツタイタクミM525	(1)
25		400-05750	FEED PLATE ASM. 5MM M525 HOOKS	ツタイタクミ5MM M525	(1)
26		400-05751	FEED PLATE ASM. 10MM M525 HOOKS	ツタイタクミ10MM M525	(1)
27		400-05757	FEED PLATE ASM. M528 670 HOOKS	ツタイタクミM528 670	(1)
28		400-05760	FEED PLATE ASM. 5MM HOOKS	ツタイタクミ5MM M528 670	(1)
29		400-05768	FEED PLATE ASM. M520 HOOKS	ツタイタクミM520	(1)
30		400-05770	FEED PLATE ASM. 5MM M520 HOOKS	ツタイタクミ5MM M520	(1)
31		400-05771	FEED PLATE ASM. 10MM M520 HOOKS	ツタイタクミ10MM M520	(1)
32		400-05794	FEED PLATE ASM. M533 HOOKS	ツタイタクミM533	(1)
33		HL-0119400-04	MEMORY IC (M508)	メモリ IC (M508)	(1)
34		HL-0119400-03	MEMORY IC (M608)	メモリ IC (M608)	(1)
35		HL-0119400-09	EP-ROM (M525)	EP-ROM (M525)	(1)
36		HL-0119400-06	EP-ROM (M528)	EP-ROM (M528)	(1)
37		HL-0119400-08	EP-ROM (M520)	EP-ROM (M520)	(1)
38		HL-0119400-11	EP-ROM (M533)	EP-ROM (M533)	(1)
39		400-06235	SEWING EYES ATTACHMENT ASM.	オサエソウクミメ5MM(M508, 608)	1
40		400-06236	SEWING EYES ATTACHMENT ASM.	オサエソウクミメ10MM(M508, 608)	1
41		400-06246	SEWING EYES ATTACHMENT ASM.	マエカノサエソウクミメ(M525)	1
42		400-06247	SEWING EYES ATTACHMENT ASM.	マエカノサエソウクミメ5MM(M525)	1
43		400-06248	SEWING EYES ATTACHMENT ASM.	マエカノサエソウクミメ10MM(M525)	1
44		400-06249	SEWING EYES ATTACHMENT ASM.	マエカノサエソウクミメ(M528)	1
45		400-06250	SEWING EYES ATTACHMENT ASM.	マエカノサエソウクミメ5MM(M528)	1
46		400-06251	SEWING EYES ATTACHMENT ASM.	マエカノサエソウクミメ(M670)	1
47		400-06252	SEWING EYES ATTACHMENT ASM.	マエカノサエソウクミメ5MM(M670)	1
48		400-06253	SEWING EYES ATTACHMENT ASM.	マエカノサエソウクミメ5MM(M520)	1
49		400-06254	SEWING EYES ATTACHMENT ASM.	マエカノサエソウクミメ5MM(M520)	1
50		400-06255	SEWING EYES ATTACHMENT ASM.	マエカノサエソウクミメ10MM(M520)	1
51		400-06256	SEWING EYES ATTACHMENT ASM.	マエカノサエソウクミメ(M533)	1
52		400-04830	SEWING EYES ATTACHMENT ASM.	アソリカ タマエカノサエソウクミメM508608	(1)
53		400-05747	SEWING EYES ATTACHMENT ASM.	アソリカ タマエカノサエソウクミメM525	(1)
54		400-05755	SEWING EYES ATTACHMENT ASM.	アソリカ タマエカノサエソウクミメM528	(1)
55		400-05756	SEWING EYES ATTACHMENT ASM.	アソリカ タマエカノサエソウクミメM670	(1)
56		400-05767	SEWING EYES ATTACHMENT ASM.	アソリカ タマエカノサエソウクミメM520	(1)
57		400-05788	SEWING EYES ATTACHMENT ASM.	アソリカ タマエカノサエソウクミメM533	(1)
58		400-05778	FEED PLATE ASM. 5MM EYES	ツタイタクミ5MM(M508 608)	(1)
59		400-05779	FEED PLATE ASM. 10MM EYES	ツタイタクミ10MM(M508 608)	(1)
60		400-05749	FEED PLATE ASM. M525 EYES	ツタイタクミM525	(1)
61		400-05752	FEED PLATE ASM. 5MM M525 EYES	ツタイタクミ5MM M525	(1)
62		400-05753	FEED PLATE ASM. 10MM M525 EYES	ツタイタクミ10MM M525	(1)
63		400-05758	FEED PLATE ASM. M528 EYES	ツタイタクミM528	(1)
64		400-05762	FEED PLATE ASM. 5MM M528 EYES	ツタイタクミ5MM M528	(1)
65		400-05759	FEED PLATE ASM. M670 EYES	ツタイタクミM670	(1)
66		400-05764	FEED PLATE ASM. 5MM M670 EYES	ツタイタクミ5MM M670	(1)
67		400-05769	FEED PLATE ASM. M520 EYES	ツタイタクミM520	(1)
68		400-05772	FEED PLATE ASM. 5MM M520 EYES	ツタイタクミ5MM M520	(1)
69		400-05773	FEED PLATE ASM. 10MM M520 EYES	ツタイタクミ10MM M520	(1)
70		400-05798	FEED PLATE ASM. M533 EYES	ツタイタクミM533	(1)
71		HL-0119400-04	MEMORY IC (M508)	メモリ IC (M508)	(1)
72		HL-0119400-09	EP-ROM (M525)	EP-ROM (M525)	(1)
73		HL-0119400-06	EP-ROM (M528)	EP-ROM (M528)	(1)
74		HL-0119400-07	EP-ROM (M670)	EP-ROM (M670)	(1)
75		HL-0119400-08	EP-ROM (M520)	EP-ROM (M520)	(1)
76		HL-0119400-11	EP-ROM (M533)	EP-ROM (M533)	(1)

8. OPTION & ATTACHMENT COMPONENTS (2)

オプション・アタッチメント関係 (2)

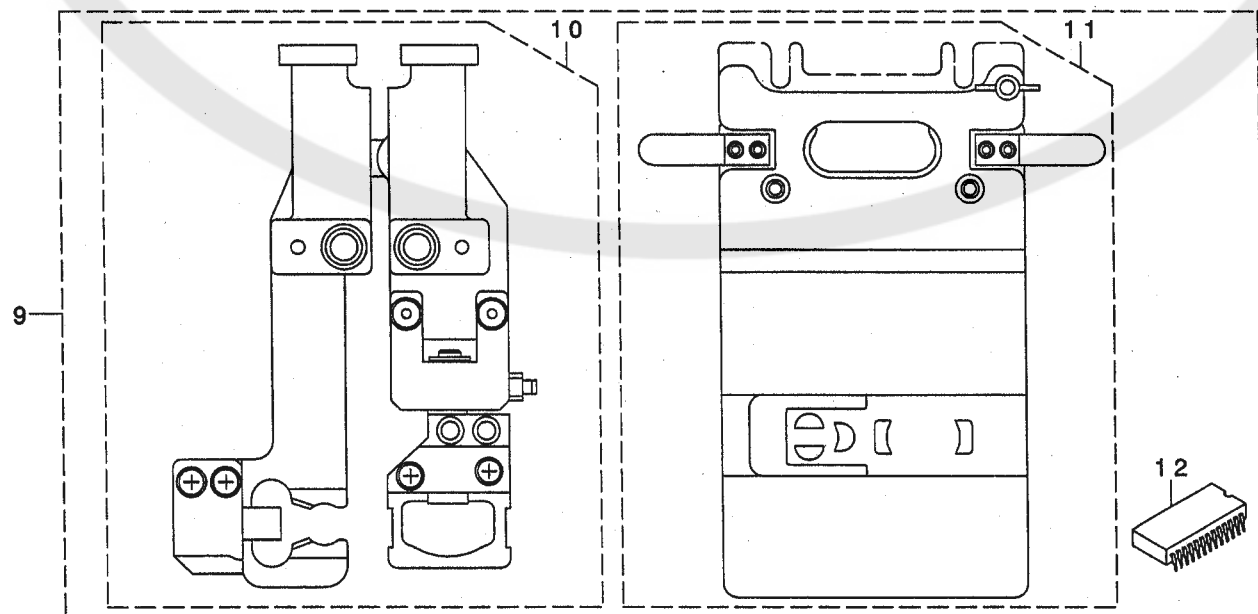
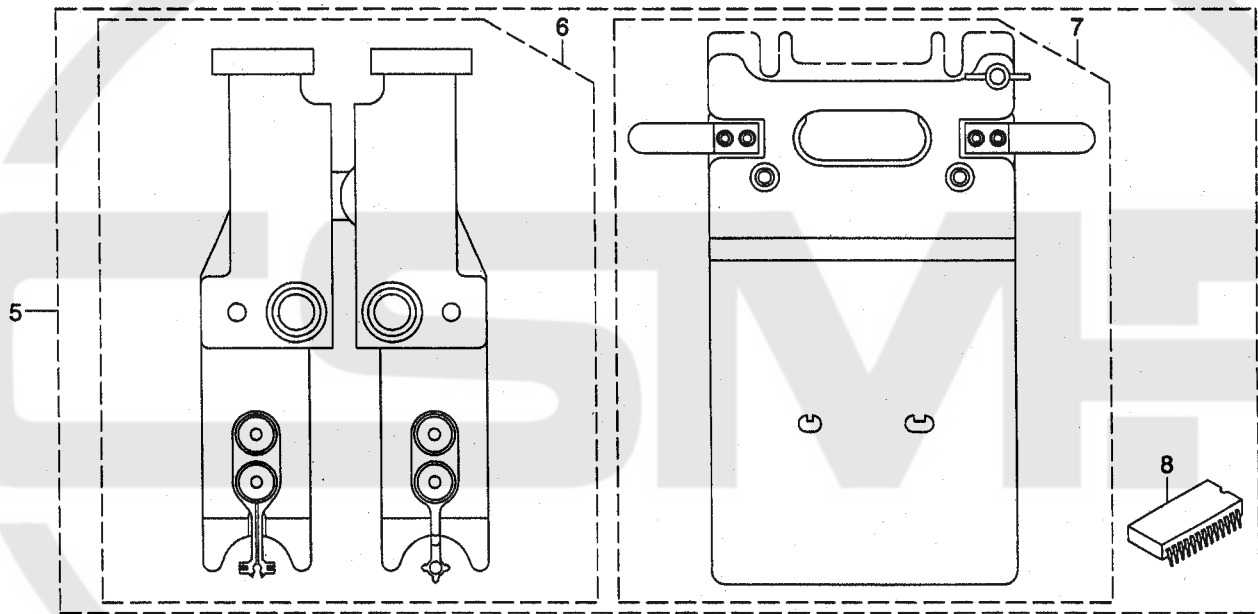
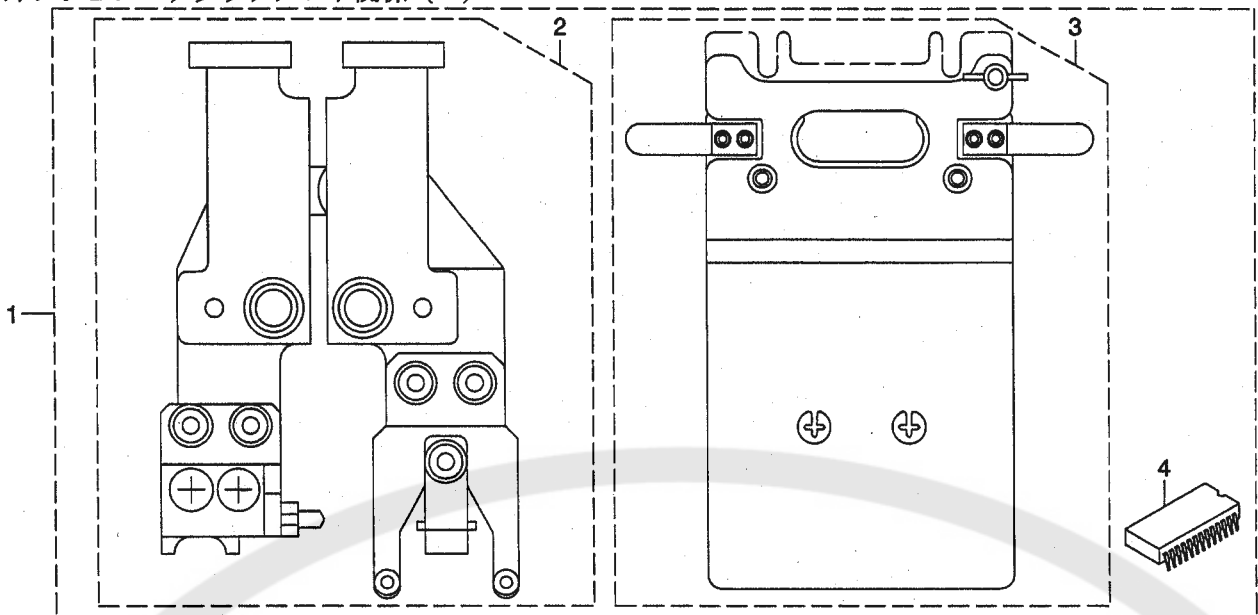

REF. NO	NOTE	PART NO.	DESCRIPTION	ヒョウメイ	Qty
1		400-06258	SPRING HOOKS ATTACHMENT ASM	ﾌﾞﾝﾘｶﾞ ﾀﾏｴｶﾝｵｻｴｿｳｸﾐ(M10)	1
2		400-05791	SPRING HOOKS ATTACHMENT ASM.	ﾌﾞﾝﾘｶﾞ ﾀﾏｴｶﾝｵｻｴｸﾐ(M10)	(1)
3		400-05797	FEED PLATE ASM.(M10)	ｼﾀｲﾀｸﾐ(M10)	(1)
4		HL-0119400-12	EP-ROM(M10)	EP-ROM(M10)	(1)
5		400-06259	SEWING SNAPS ATTACHMENT ASM.	ﾌﾞﾝﾘｶﾞ ﾀﾏｴｶﾝｵｻｴｿｳｸﾐ(SW2)	1
6		400-05793	SEWING SNAPS ATTACHMENT ASM.	ﾌﾞﾝﾘｶﾞ ﾀﾏｴｶﾝｵｻｴｸﾐ(SW2)	(1)
7		400-05799	FEED PLATE ASM.(SW2)	ｼﾀｲﾀｸﾐ(SW2)	(1)
8		HL-0119400-05	MEMORY IC(SW2)	ﾒﾓﾘIC(SW2)	(1)
9		400-06257	SEWING HOOKS ATTACHMENT ASM.	ﾌﾞﾝﾘｶﾞ ﾀﾏｴｶﾝｵｻｴｿｳｸﾐ(M510)	1
10		400-05789	SEWING HOOKS ATTACHMENT ASM.	ﾌﾞﾝﾘｶﾞ ﾀﾏｴｶﾝｵｻｴｸﾐ(M510)	(1)
11		400-05796	FEED PLATE ASM.(M510)	ｼﾀｲﾀｸﾐ(M510)	(1)
12		HL-0119400-10	EP-ROM(M510)	EP-ROM(M510)	(1)



NUMERICAL INDEX OF PARTS

索引

PART NO 品番	PAGE 頁	REF NO	PART NO 品番	PAGE 頁	REF NO	PART NO 品番	PAGE 頁	REF NO	PART NO 品番	PAGE 頁	REF NO
B1504-280-000	6	18	SM-3030552-TN	4	18	400-04830	4	2	400-06238	12	8
B2101-220-OA0	5	1	SM-4020301-SC	2	23	400-04830	12	52	400-06239	12	9
B2101-220-000	5	16	SM-4030601-SN	6	8	400-04831	4	19	400-06240	12	10
B2102-205-OAA	5	5	SM-4030801-SN	6	13	400-04832	4	4	400-06241	12	11
B2103-220-000	5	17	SM-6030402-TN	2	44	400-04833	4	5	400-06242	12	12
B2104-220-000	5	2	SM-6030402-TN	4	32	400-04834	4	6	400-06243	12	13
B2106-220-000	5	3	SM-6040502-TN	2	42	400-04835	4	7	400-06244	12	14
B2107-210-000	5	4	SM-6040502-TN	4	30	400-04836	4	8	400-06245	12	15
B8101-205-OBA	8	3	SM-6040802-TN	2	17	400-04837	4	9	400-06246	12	41
B8102-205-OAA	8	4	SM-6040802-TN	4	13	400-04838	4	10	400-06247	12	42
			SM-9082023-SE	8	12	400-04839	4	20	400-06248	12	43
D1129-205-K0A-A	6	3	SS-6090630-TP	5	6	400-04840	4	27	400-06249	12	44
D2570-205-K0A	6	9	SS-7110840-SP	5	18	400-04841	4	28	400-06250	12	45
D8307-205-K0A	8	7	SS-7111120-SP	5	7	400-04842	4	29	400-06251	12	46
D8308-205-K0A	8	8	SS-7151210-SP	6	15	400-04843	4	21	400-06252	12	47
D8310-205-KAA	6	1	SS-9151210-TP	10	9	400-04844	4	22	400-06253	12	48
						400-04850	2	4	400-06254	12	49
EA-9500B00-00	6	10	WP-0320501-SC	6	2	400-04850	12	17	400-06255	12	50
EA-9500B01-00	5	25	WP-0320501-SC	6	14	400-04851	2	26	400-06256	12	51
E8760-452-D00	6	11	WP-0371016-SD	5	11	400-04852	2	7	400-06257	14	9
			WP-0450826-SC	2	18	400-04853	2	30	400-06258	14	1
G6214-345-000	6	12	WP-0450826-SC	2	43	400-04854	2	31	400-06259	14	5
			WP-0450826-SC	4	14	400-04855	2	32			
HA-0028300-00	6	4	WP-0450826-SC	4	31	400-04860	8	2			
HK-0188000-20	5	15	WP-0561616-SC	5	12	400-04861	6	16			
HK-0188200-20	5	23	WP-0641601-SD	6	17	400-05742	2	1			
HK-0346100-2B	5	20	WS-0210002-KN	2	24	400-05743	2	2			
HK-0346400-00	5	21	WS-0310002-KR	2	45	400-05744	4	1			
HL-0119400-03	2	47	WS-0310002-KR	4	33	400-05746	12	18			
HL-0119400-03	4	35	WS-0861410-KR	8	14	400-05747	12	53			
HL-0119400-03	10	3				400-05748	12	26			
HL-0119400-03	12	36	142-17764	2	5	400-05749	12	64			
HL-0119400-04	2	46	142-17764	4	3	400-05750	12	27			
HL-0119400-04	4	34	161-37804	2	36	400-05751	12	28			
HL-0119400-04	10	2	161-37804	4	26	400-05752	12	66			
HL-0119400-04	12	35	170-07105	8	18	400-05753	12	58			
HL-0119400-04	12	71	170-07204	8	9	400-05754	12	19			
HL-0119400-05	10	4	170-07402	8	11	400-05755	12	54			
HL-0119400-06	12	38	170-07907	8	13	400-05756	12	55			
HL-0119400-06	12	73	170-08004	8	15	400-05757	12	29			
HL-0119400-07	12	74	170-08103	8	16	400-05758	12	60			
HL-0119400-08	12	39	178-48458	10	6	400-05759	12	63			
HL-0119400-08	12	75	178-48508	10	7	400-05760	12	30			
HL-0119400-09	12	37	180-77909	8	5	400-05762	12	61			
HL-0119400-09	12	72	180-78006	8	6	400-05764	12	65			
HL-0119400-10	14	12	180-78204	8	10	400-05766	12	20			
HL-0119400-11	12	40				400-05767	12	56			
HL-0119400-11	12	76	400-04806	2	3	400-05768	12	31			
HL-0119400-12	14	4	400-04806	12	16	400-05769	12	67			
HL-0119400-13	14	8	400-04807	2	25	400-05770	12	32			
HP-0002002-00	5	14	400-04808	2	6	400-05771	12	33			
HP-0006002-10	5	22	400-04809	2	8	400-05772	12	68			
HW-0005900-20	5	24	400-04810	2	9	400-05773	12	69			
HW-5001400-00	6	5	400-04811	2	10	400-05774	12	22			
			400-04812	2	11	400-05775	12	23			
MAI-15040000	6	7	400-04813	2	12	400-05776	12	24			
MAT-81126T00	6	6	400-04814	2	13	400-05777	12	25			
MDP-170B1400	8	1	400-04814	4	11	400-05778	12	59			
MDP-170B1402	10	5	400-04815	2	14	400-05779	12	62			
M8601-592-ABO	10	1	400-04816	2	15	400-05787	12	21			
M9060-592-OAO	5	19	400-04817	2	27	400-05788	12	57			
			400-04818	2	33	400-05789	14	10			
NM-6040003-SC	5	13	400-04818	4	23	400-05791	14	2			
NM-6120003-SE	8	17	400-04819	2	34	400-05793	14	6			
			400-04819	4	24	400-05794	12	34			
SD-0600352-SP	5	8	400-04820	2	35	400-05796	14	11			
SD-0640321-SP	5	9	400-04820	4	25	400-05797	14	3			
SD-0640321-SP	5	10	400-04822	2	37	400-05798	12	70			
SK-3412001-SE	10	8	400-04823	2	38	400-05799	14	7			
SM-1030601-SC	2	22	400-04824	2	39	400-06231	12	1			
SM-1030801-SR	2	21	400-04825	2	40	400-06232	12	2			
SM-1030801-SR	4	17	400-04826	2	41	400-06233	12	3			
SM-3030552-TN	2	19	400-04827	2	28	400-06234	12	4			
SM-3030552-TN	2	20	400-04828	2	29	400-06235	12	5			
SM-3030552-TN	4	15	400-04829	2	16	400-06236	12	6			
SM-3030552-TN	4	16	400-04829	4	12	400-06237	12	7			



JUKI®

JUKI CORPORATION

INTERNATIONAL SALES H.Q.
8-2-1, KOKURYO-CHO, CHOFU-SHI
TOKYO 182-8655, JAPAN
PHONE : (81)3-3430-4001 to 4005
FAX : (81)3-3430-4909 . 4914 . 4984
TELEX : J22967

Copyright © 2002 JUKI CORP.
本書の内容を無断で転載、複写すること
を禁止します。
All rights reserved throughout the world.

JUKI 株式会社

〒182-8655 東京都調布市国領町8-2-1
TEL. 03-3480-1111(代表)

営業本部
TEL. 03-3430-4001(ダイヤルイン)

お問い合わせ、ご相談は
To order or for further
information,
please contact:

※このパーツリストは商品改良のため予告なく変更する事があります。
*The description covered in this parts list is subject to change for improvement of the commodity without notice.
※このパーツリストは、2002年5月 現在の商品仕様で編集したものです。
*This parts list is edited in accordance with the product specifications as of May 2002.